

HL2 SERIES TUBE HEATERS

ENGINEERING SUBMITTAL DATA – TWO-STAGE LOW INTENSITY GAS FIRED INFRA-RED TUBE HEATERS & ACCESSORIES

SUBMITTED BY: _____

DATE: _____

JOB TITLE: _____

CONTRACTOR: _____

ADDRESS: _____

PHONE #: _____

CITY: _____

ADDRESS: _____

STATE: _____ ZIP: _____

CITY: _____

STATE: _____ ZIP: _____

ENGINEER: _____

LOCAL REPRESENTATIVE: _____

NOTES: _____

										FIELD USE ONLY**	
QTY.	MODEL #	GAS TYPE (Circle One)	BTU'S High Fire	BTU'S Low Fire	STRAIGHT LENGTH	U-TUBE LENGTH	STANDARD WEIGHT	STAINLESS STEEL WEIGHT	RECOMMENDED MOUNTING HEIGHTS^	"TYPE" TUBE PKG #1	"TYPE" TUBE PKG #2
	HL2-20-65	N or LP	65,000	50,000	21' - 7"	13' - 0"	120 lbs.	N/A	9' - 14'	20-4 ALUM	N/A
	HL2-20-75	N or LP	75,000	50,000	21' - 7"	13' - 0"	120 lbs.	145#	10' - 15'	20-4 ALUM	N/A
	HL2-20-100	N or LP	96,000	65,000	21' - 7"	13' - 0"	120 lbs.	N/A	11' - 18'	20-4 ALUM	N/A
	HL2-30-65	N or LP	65,000	50,000	31' - 3"	*17' - 10"	160 lbs.	N/A	10' - 15'	30-4 ALUM	N/A
	HL2-30-75	N or LP	75,000	50,000	31' - 3"	*17' - 10"	160 lbs.	195#	11' - 18'	30-4 ALUM	N/A
	HL2-30-100	N or LP	100,000	65,000	31' - 3"	*17' - 10"	160 lbs.	195#	12' - 20'	30-4 ALUM	N/A
	HL2-30-125	N or LP	125,000	95,000	31' - 3"	*17' - 10"	160 lbs.	N/A	13' - 23'	30-4 ALUM	N/A
	HL2-40-65	N or LP	65,000	50,000	40' - 11"	22' - 8"	190 lbs.	N/A	11' - 18'	40-4 ALUM	N/A
	HL2-40-75	N or LP	75,000	50,000	40' - 11"	22' - 8"	190 lbs.	235#	11' - 18'	40-4 ALUM	N/A
	HL2-40-100	N or LP	100,000	65,000	40' - 11"	22' - 8"	190 lbs.	235#	12' - 20'	40-4 ALUM	N/A
	HL2-40-125	N or LP	125,000	95,000	40' - 11"	22' - 8"	190 lbs.	235#	13' - 23'	40-4 ALUM	N/A
	HL2-40-150	N or LP	150,000	100,000	40' - 11"	22' - 8"	190 lbs.	235#	14' - 25'	40-4 TITAN	N/A
	HL2-40-175	N or LP	175,000	125,000	40' - 11"	22' - 8"	190 lbs.	N/A	15' - 27'	40-4 TITAN	N/A
	HL2-50-125	N or LP	125,000	95,000	50' - 7"	*27' - 6"	235 lbs.	290#	15' - 27'	40-4 ALUM	10-4 ALUM
	HL2-50-150	N or LP	150,000	100,000	50' - 7"	*27' - 6"	235 lbs.	290#	15' - 27'	40-4 TITAN	10-4 ALUM
	HL2-50-175	N or LP	175,000	125,000	50' - 7"	*27' - 6"	235 lbs.	N/A	16' - 30'	40-4 TITAN	10-4 ALUM
	HL2-50-200	N or LP	200,000	145,000	50' - 7"	*27' - 6"	235 lbs.	N/A	17' - 35'	40-4 TITAN	10-4 ALUM
	HL2-60-150	N or LP	150,000	100,000	60' - 3"	32' - 4"	265 lbs.	330#	16' - 30'	40-4 TITAN	20-4 ALUM
	HL2-60-175	N or LP	175,000	125,000	60' - 3"	32' - 4"	265 lbs.	N/A	16' - 30'	40-4 TITAN	20-4 ALUM
	HL2-60-200	N or LP	200,000	145,000	60' - 3"	32' - 4"	265 lbs.	N/A	17' - 35'	40-4 TITAN	20-4 ALUM
	HL2-70-175	N or LP	175,000	125,000	69' - 11"	*37' - 2"	300 lbs.	N/A	19' - 42'	40-4 TITAN	30-4 ALUM
	HL2-70-200	N or LP	200,000	145,000	69' - 11"	*37' - 2"	300 lbs.	N/A	19' - 42'	40-4 TITAN	30-4 ALUM

* Model requires 5EA-SUB accessory package when installing in a 'U' configuration.

** Type packages refer to the tube package that will ship with models (length, diameter, combustion tube type and radiant tubes).

^ Recommended mounting heights are provided as a guideline. Actual conditions may dictate variations from this data.

N/A: Not Available or Not Applicable.

DETROIT RADIANT PRODUCTS CO.



21400 Hoover Rd.
Warren, MI 48089-3162

Phone: (586) 756-0950
Toll Free: 1-800-222-1100
Fax: (586) 756-2626
Email: sales@detroitradiant.com
Website: www.detroitradiant.com

VISIT OUR WEBSITE FOR:

- Product Specs
- Parts Support
- Dealer Locator
- Applications
- C.A.D. Library
- Design Guidelines
- Theory of Infra-red
- and More!

HL2 SPECIFICATIONS

APPROVALS

- IAS, CGA, CSA (CE-EHL Series).
- Indoor/Outdoor Approval (with OD-Kit).
- Commercial/Industrial Approval.

BURNER CONTROL BOX

- Sight glass for burner inspection.
- Totally enclosed components.
- Coated enameled steel.
- Operational & self-diagnostic indicator lights.

GAS CONNECTION

- 7/8" flare-M FPT Connection to 1/2" x 24" (304) SS flex connector provided.
- 1/2" F NPT ball valve & inlet tap included.

COMBUSTION AIR INLET & VENTING

- Preset 4" combustion air inlet collar.
- Sidewall or roof venting.

GAS SUPPLY – W.C.P. NAT LP

- Manifold pressure 3.5" 10.0"
- Min. Inlet pressure 5.0" 11.0"
- Max. Inlet pressure 14.0" 14.0"

POWER SUPPLY

- 120 V.A.C., 60 Hz GRD, 1 Ph., 3-wire.
- 24V thermostat connection.
- Ignition current - 4.8 amps.
- Running current - 1.1 amps.

CONTROLS

- Two-stage gas valve (at 100% and 65%).
- Air proving safety switch.
- Silicon carbide hot surface igniter.
- Pre and post purge controls.
- Flame rod sensing.
- 24V thermostatic control voltage.
- Self-diagnostic – LED "soft lockout".

EMITTER & COMBUSTION TUBES

- 16ga. 4" O.D. aluminized coated steel radiant emitter tubes.
- Titanium coated combustion chamber (150-200 MBH models).
- All tubes coated with high temperature, corrosion resistant black coating, .95 emissivity. Slip-fit swaged connection.
- Turbulator baffle.

REFLECTOR

- Highly polished aluminum.
- Two end caps included.
- Reflector tension springs.
- Continuous overlap design.
- One reflector center support per reflector.

LIMITED WARRANTY

- 1 year - Burner box components.
- 5 years - Combustion and radiant tubes.
- 10 years - Burner.

CLEARANCES TO COMBUSTIBLES (IN.)

MODEL NO.	MOUNTING ANGLE*	SIDE			
		FRONT	BEHIND	TOP	BELOW
HL2 (20, 30, 40) - 65, 75 [N,P]	0°	9	9	6	60
	45°	39	8	10	60
W/1 side shield	0°	29	8	6	60
W/2 side shields	0°	9	9	6	60
20 ft. from burner	0°	7	7	6	30
HL2 (20, 30, 40) - 100 [N,P]	0°	14	14	6	66
	45°	39	8	10	66
W/1 side shield	0°	29	8	6	66
W/2 side shields	0°	16	16	6	66
20 ft. from burner	0°	7	7	6	30
HL2 (30, 40, 50) - 125 [N,P]	0°	20	20	6	76
	45°	58	8	10	76
W/1 side shield	0°	42	8	6	76
W/2 side shields	0°	20	20	6	76
20 ft. from burner	0°	7	7	6	30
HL2 (40, 50, 60) - 150 [N,P]	0°	24	24	6	81
	45°	58	8	10	81
W/1 side shield	0°	42	8	6	81
W/2 side shields	0°	23	23	6	81
20 ft. from burner	0°	11	11	6	44
HL2 (40, 50, 60, 70) - 175 [N,P]	0°	34	34	6	92
	45°	63	8	10	92
W/1 side shield	0°	50	8	6	92
W/2 side shields	0°	30	30	6	92
20 ft. from burner	0°	11	11	6	44
HL2 (50, 60, 70) - 200 [N,P]	0°	41	41	6	94
	45°	63	8	10	94
W/1 side shield	0°	54	8	6	94
W/2 side shields	0°	30	30	6	94
20 ft. from burner	0°	11	11	6	44

* Heaters mounted on an angle between 0° and 45° must maintain clearances posted for 0° or 45°; whichever is greater.

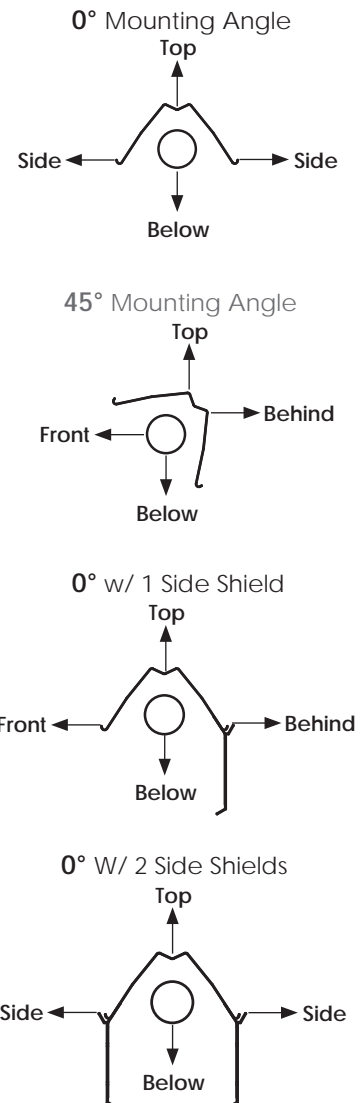

Read and understand the installation, operation and maintenance manual prior to installing or servicing this unit.

In locations used for the storage of combustible materials, signs must be posted adjacent to the heater's thermostat specifying stacking heights.

FIELD DATA

Burner Control Box with U-Bend • End View

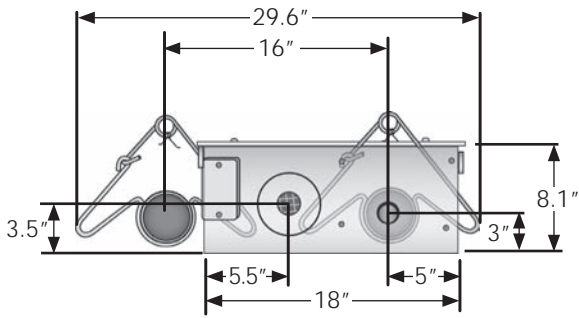

Side View

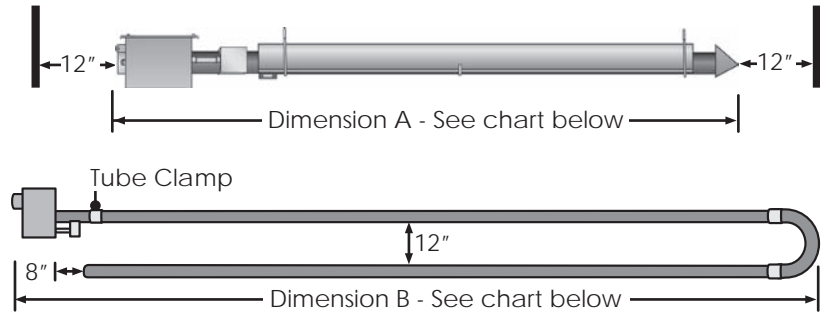
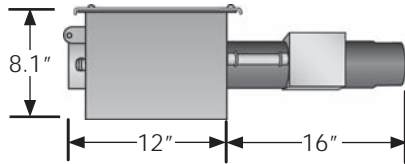

MODEL NUMBER	DIMENSION A STRAIGHT	DIMENSION B U-TUBE
HL2-20	21' - 7"	13' - 0"
HL2-30	31' - 3"	*17' - 8"
HL2-40	40' - 11"	22' - 8"
HL2-50	50' - 7"	*27' - 4"
HL2-60	60' - 3"	32' - 4"
HL2-70	69' - 11"	*37' - 2"

*with 5EA-SUB

OPTIONAL ACCESSORIES

QTY	PART #	DESCRIPTION	NOTES
	10EA	10' X 4" Tube & Reflector Extension	Optional 10' extension package. Max. one per unit.
	4-DSK	4" Sidewall Vent Kit	Required for all single sidewall vents. No roof venting.
	6-DSK	6" Sidewall Vent Kit	Required for all common sidewall vents. No roof venting.
	BK	Angle Mounting Bracket 15-30-45 Deg.	Rotates unit to preset mounting angles.
	E6	90 Degree, 4" Radiant Elbow	Used for making a 'L' tube shaped heater. Max. two per unit.
	PG	Protective Guard	Protects heat exchanger from contact or objects. Each 5' in length.
	PLQ	Warning Plaque	Hung below heater, restates the clearance to combustible warning.
	REP	Reflector & Elbow Package	Reflector and accessories used to configure heater in a 'L' shape.
	RTVP-4	4" Rooftop Vent Package	Used to vent vertically through the roof.
	RTVP-6	6" Rooftop Vent Package	Used to vent vertically through the roof.
	RUP	Reflector & 'U' Bend Package	Reflector and accessories used to configure heater in a 'U' shape.
	SMB	Single Mount Bracket	Provides units with 'U' bend uniform mounting points. One per 10'.
	SSE	Side Shield Extension	Reflector side guard used to lower side clearances. Each 5' in length.
	TF1B	180 Degree, 4" Radiant 'U' Bend	Used for making a 'U' shaped heater. Max. one per unit.
	TR60	5' x 4" Tube & Reflector Extension	Optional 5' extension package. Max two per unit.
	WIV-4	4" Combustion Air Intake - Sidewall Cap	Used to duct fresh (cold) air 0-30 ft. to a heater. Sidewall only.
	WVE-GALV	4" Unvented Exhaust Termination Cap	Required on all units when operating unvented.
	Y	4" x 4" x 6" Common 'Y' Vent Fitting	Used for joining two heaters on one vent. Same T-stat required.
	YSM	4" x 6" x 4" Common 'Y' Vent Fitting	Used for joining two heaters on one vent. Same T-stat required.

OPTIONAL UPGRADES

- SILSEAL** Protects internal burner box components against contaminants.
- OD-KIT** For use when applying heaters outdoors.
- PC-36** Three prong power cord set. Allows heater to be plugged into 120V grounded outlet.
- HLRB** Relay board, required on heaters sharing a common thermostat or a single vent.
- 5EA-SUB** Substitute one 10' radiant tube and reflector for two 5' pieces. This is ideal for making "U" heaters from 30', 50' and 70' models. Maximum of one per heater.

STAINLESS STEEL UPGRADES

- SSCBAO** - Control Box
- SSRAO** - Reflectors
- SSTAO** - Tubes (75-150 MBH only)
- SSTRAO** - Tubes & Reflectors (75-150 MBH only)
- SSB-##** - Mounting Brackets (## = heater length)

NOTE: Refer to the Tube Heater AccessoryBook for detailed specifications and limitations on any of the above options.

WRITTEN SPECIFICATIONS

HEATER PARAMETER/SPECIFICATIONS

- Gas fired two-stage radiant tube heaters shall be furnished and installed in accordance with governing codes and as shown per drawing(s) provided. Two-stage radiant tube heaters shall be RE-VERBER-RAY HL2 SERIES of the model numbers and input(s) in BTU/H as manufactured by Detroit Radiant Products Company, Warren, MI 48089.
- Two-stage radiant tube heaters shall be Design Certified by CSA and comply with current Occupational Safety and Health Act (OSHA) Requirements. The supplier shall provide the CSA Certification Number and the heaters shall bear the CSA Seal of Certification. The heaters low fire and high fire modes of operation must be Design Certified by CSA.
- The supplier shall provide a manufacturer's published warranty covering the heater's stainless steel burner for a period of ten (10) years, combustion and radiant emitter tube assembly for a period of five (5) years, and all components utilized in the heater control assembly for a period of one (1) year.
- The supplier shall furnish the owner/contractor with _____ copies of the engineering specification form, showing physical dimensions, installation detail, recommendations, control wiring diagrams, and spare parts list.
- Two-stage radiant tube heaters shall be designed to satisfactorily operate at a minimum inlet pressure of ____ inches W.C. to a maximum inlet pressure of ____ inches W.C.
- Two-stage radiant tube heaters shall be designed to operate without adjustments when burning natural gas having a heat value of ____ BTU per cubic foot with a specific gravity of ____; or when burning propane gas, have a heat value of 2500 BTU per cubic foot with a specific gravity of 1.53.
- An Installation, Operation, and Maintenance Manual shall be supplied with each heater.

TWO-STAGE RADIANT TUBE HEATER BURNER CONTROLS

- The two-stage radiant tube heater's normal sequence of operation shall include a defined input differential. Heater must be CSA Design Certified to operate at an input differential of at least 30% between the low fire and high fire modes.
- Heaters shall be equipped with a direct silicon carbide ignition system with a three (3)-time ignition trial to sensing mode and an infinite trial after sensing mode. Power supplied to each burner shall be 120 VAC, 60 Hz. Flame sensing shall be via an independent sensing rod and circuit.
- The control assembly shall be Design Certified by CSA, shall provide main burner regulation, and shall be of the redundant type.
- Heater controls shall include a safety differential pressure switch to monitor combustion air flow, so as to provide complete burner shutdown due to insufficient combustion air or flue blockage.
- The heater shall incorporate a self-diagnostic ignition module, include an external LED readout display, and recycle the heater after an inadvertent shutdown.
- The heater's control system shall be designed to shut off the gas flow to the main burner in the event either a gas supply or power supply interruption occurs.

- The heater's blower motor shall be thermally protected and the motor's impeller shall be balanced.
- The heater's air flow control system shall provide a 45 second pre-purge prior to initiating burner operation and a 90 second post-purge upon completion, effectively removing all products of combustion from heat exchanger and/or radiant tubes.
- Heater control assembly shall include staging indicator lights that define the units operating input ranges.
- No condensation shall form as a result of combustion in the combustion chamber or radiant tubes while at operating temperatures.
- The thermostats shall be two-stage operating on 24 volts.
- Total heater shutdown shall occur in the event of circuit control lockout, including burner operation and combustion air blower. An interruption of power (reset thermostat) will restart the firing sequence.
- The heater controls shall provide a 90 second post-purge as an integral part of the control assembly.

TWO-STAGE RADIANT TUBE HEATER CONSTRUCTION

- Heater's control housing shall be totally enclosed with a corrosion resistant enameled steel exterior. The controls shall be easily serviceable by removing one (1) panel.
- The main burner assembly shall be constructed of stainless steel.
- Heater's combustion chamber shall be 4" O.D. 16ga. aluminized w/titanium coated (150-200MBH) or aluminized coated (75-125MBH) steel, finished with a high emissivity rated, corrosion resistant, black coating.
- Heater's radiant emitter tube shall be 4" O.D. 16ga. aluminized steel finished with a high emissivity rated, corrosion resistant, black coating.
- The heater's combustion chamber and radiant emitter tube shall incorporate a 4" slip-fit, interlocking connection in which the upstream tube slides into the next tube and is held by a bolted clamp.
- The silicon carbide igniter shall be readily accessible and serviceable without the use of tools.
- Reflectors shall be .025 polished aluminum with a multi-faceted design which includes reflector end caps. Reflectors shall be rotatable from 0 to 45 degrees when required. The heater's reflector hanging system shall be designed to permit expansion while minimizing noise and/or rattles. Reflectors shall be assembled to the heater without the use of tools.
- The heaters shall utilize a downstream turbulator baffle for maximum thermal efficiency.
- Heaters shall be equipped with a sight glass allowing a visual inspection of igniter and burner operation from the floor.
- The two-stage radiant tube heaters shall be designed such that, at the customer's option, outside combustion air may be supplied without the use of additional supply fans. An air intake collar shall be supplied as part of the burner control assembly to accept a 4" O.D. supply duct.